

# UG-25<sup>+</sup>

## Governor

### Description

The Woodward UG-25<sup>+</sup> governor is a microprocessor-controlled, mechanical-hydraulic amplified, governor for controlling diesel, gas, and dual fuel engines, and steam turbines.

Enhanced control capabilities, such as start fuel and boost limiting schemes, are an integral part of the UG-25<sup>+</sup> governor. The additional transient fuel limiting (jump-rate) improves the engine load acceptance and reduces transient emissions significantly.

This fast-acting, high-work-output governor has no need for any auxiliary devices such as a start booster or oil cooler. Two work output versions are available.

The UG-25<sup>+</sup> offers speed control with software-selectable speed set points, dynamics, fuel limiting, and start behavior. All it takes is a PC to adjust and download configuration data.

Front panel and external speed settings make synchronization and load sharing easy for generator applications. A 4 mA to 20 mA speed setting is available for variable speed applications.

Adjustable droop permits load division and balancing among parallel operated prime movers. Droop can be set with a knob on the front panel between 0–10. The load limiter knob allows you to limit the governor output manually.

The UG-25<sup>+</sup> uses a 1034 kPa (150 psi) internal operating pressure with an internal oil pump driven from the governor's drive shaft, available in either a keyed or serrated configuration. Oil pressure is maintained by a relief valve system with a drain to an internal oil sump.

Control features:

- State-of-the-art speed sensing and control algorithms
- Enhanced PID dynamics
- Configurable speed settings and adjustment rates
- Multiple fuel limiting algorithms, such as jump-rate, boost pressure, and start fuel limiting
- Comprehensive diagnostics for easy troubleshooting

The UG-25<sup>+</sup> is a drop-in replacement for UG-8 and 3161 governors and combines all the advantages of a traditional mechanical governor with the state-of-the-art control algorithms for optimal engine operation.



- Suitable for gasoline, gaseous, and diesel fueled engines
- Convenient front panel adjustments
- Speed setting with standard 4 mA to 20 mA signal or using raise/lower commands
- Easy setup and tuning using PC-based Service Tool
- Discrete output driver for status indication
- Isochronous or droop control
- Drop-in replacement for UG-8 and 3161 governors
- 34 J (25 ft-lb) & 41 J (31 ft-lb) versions available
- Available with either a keyed or serrated drive shaft
- Compliant with applicable CE Directives—EMC, Pressure Equipment, Machinery
- Certified for use in marine applications

## Specifications

### Governor

|                   |                                       |
|-------------------|---------------------------------------|
| Power Supply      | (18 to 32) V (dc), dual inputs        |
| Power Consumption | Reverse polarity protection, 32 W max |

#### Torque/Work Output (minimum):

|   |   |
|---|---|
| Standard Version<br>(0.625 inch diameter terminal shaft)        | 45.4 N·m (33.5 lb-ft) torque; 32.9 J (24.3 ft-lb) of work over 42 degrees |
| Increased Output Version<br>(0.75 inch diameter terminal shaft) | 55.5 N·m (40.9 lb-ft) torque; 40.2 J (29.6 ft-lb) of work over 42 degrees |

|                         |   |
|-------------------------|---|
| Max. Continuous Speed   | 1700 rpm (gov. shaft) max (small pump);<br>1200 rpm (gov. shaft) max (large pump) |
| Hysteresis              | 1.0 % or less (measured over full terminal shaft travel)                          |
| Temperature Drift       | 1.0 % of full terminal shaft travel between 27 °C and 77 °C (80 °F and 170 °F)    |
| Linearity               | 2.5 % or less (measured over full terminal shaft travel)                          |
| Ramp-up Rate            | Configurable from 0.2 to 200 rpm/s (gov. shaft)                                   |
| Steady State Speed Band | ±0.25% of rated speed (under normal operating conditions)                         |
| Weight                  | 28 kg (62 lb), dry weight   |
| Customer Connections    | Terminal blocks located inside front access plate                                 |

### Governor Drive / Hydraulic System

|                             |   |
|-----------------------------|---|
| Input Shaft Options         | 0.625 keyed drive shaft with 0.625-18 threads or 0.625-36 serrated  |
| Output                      | 42.2 ± 0.6 degrees rotary   |
| Terminal Shaft Options      | 0.625-36 serration (standard), 0.750-36 serration (increased output version)  |
| Drive Power Requirement     | 335 W (0.45 hp) max.  |
| Internal Hydraulic Pressure | 1034 kPa (150 psi)  |
| Oil                         | Self-contained sump (2.1 L / 2.2 quart capacity). See Woodward Manual 25071, <i>Oils for Hydraulic Controls</i> , for oil recommendations.            |
| Drive Speed                 | Available with either high or low speed pump<br>High-speed pump: 500 rpm to 1700 rpm (gov. shaft)<br>Low Speed pump: 350 rpm to 1200 rpm (gov. shaft) |
| Drive Rotation              | Pump can be configured to operate in CW or CCW direction  |

### Functions

|                         |  |
|-------------------------|--|
| Function Options        | Start Fuel Limiter; Adjustable Max Fuel Stop; Jump and Rate Limiter; Position-based Gain curve; Manifold Air Pressure Biased Fuel Limiter, Analog set-point rate limit; separate Raise and Lower Rates; Start Gain   |
| Programming Port I/O    | Programmable with Windows GUI software and harness<br>4 mA to 20 mA analog speed setting; Analog Speed Set-point selector<br>Raise, Lower, and Stop discrete inputs<br>Analog Speed Set Enable discrete input<br>4 mA to 20 mA boost fuel limiter input; Boost Input selector<br>Unit Healthy discrete out |
| Front Panel Functions   | Raise and Lower speed set-point commands<br>Stop command; Droop adjustment; Stability adjustment, Fuel-Limit adjustment  |
| Front Panel Indications | Unit Healthy status indication, Speed Set-point mode indications (Raise/Lower or Analog)   |

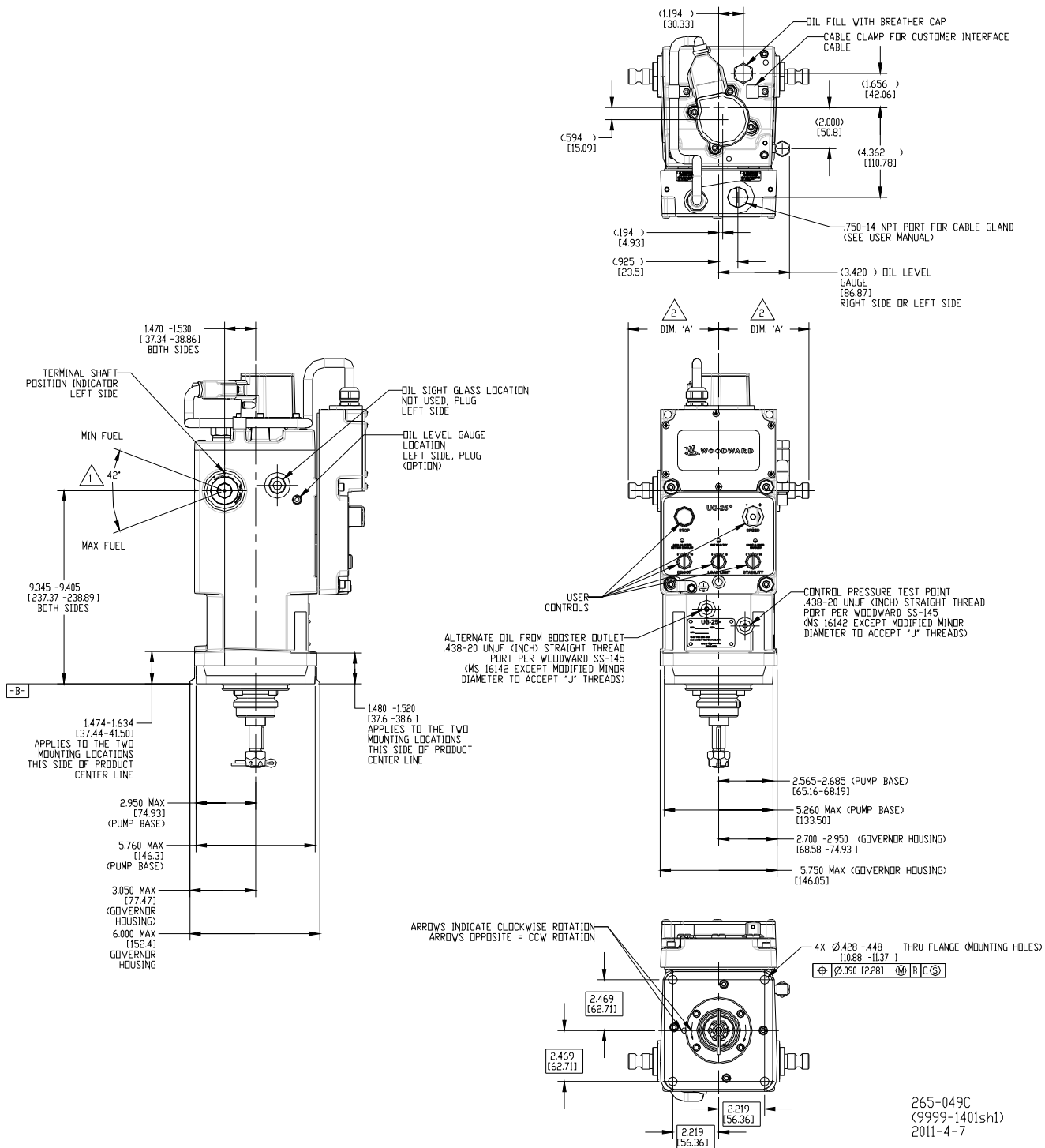

**UG-25+ Outline Drawing (Do Not Use for Construction)**

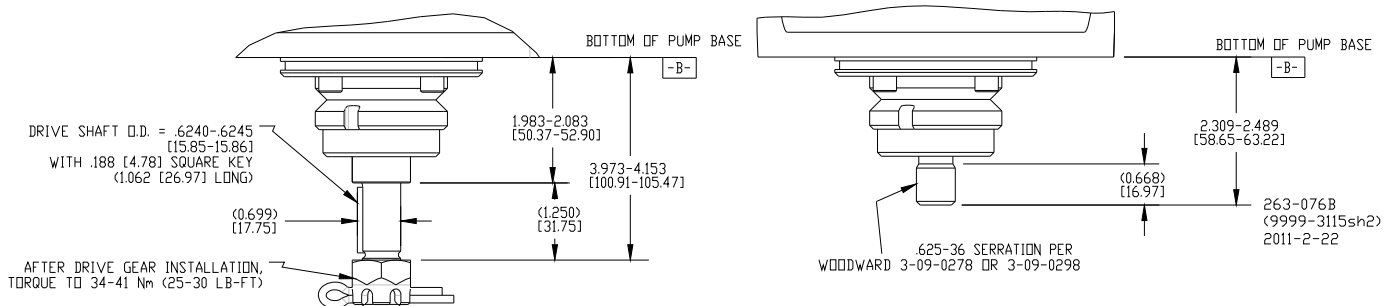

**Drive Shaft Options**

## Specifications (continued)

### Environment

|                               |   |
|-------------------------------|---|
| Ambient Operating Temperature | 0 °C to 55 °C (32 °F to 131 °F)   |
| Governor Case Temperature     | 100 °C (212 °F) maximum   |
| Storage Temperature           | -40 °C to +85 °C (-40 °F to +185 °F), limited by electronics  |
| EMC                           | EN61000-6-2: Immunity for Industrial Environments<br>EN61000-6-4: Emissions for Industrial Environments   |
| Humidity                      | US MIL-STD 810E, Method 507.3, Procedure III  |
| Shock                         | MS1-40G 11 ms saw tooth   |
| Vibration Validation          | Power Spectral Density (PSD) must not exceed the level or frequency as shown in the curve while the governor is running on a loaded engine, as measured at governor base. |

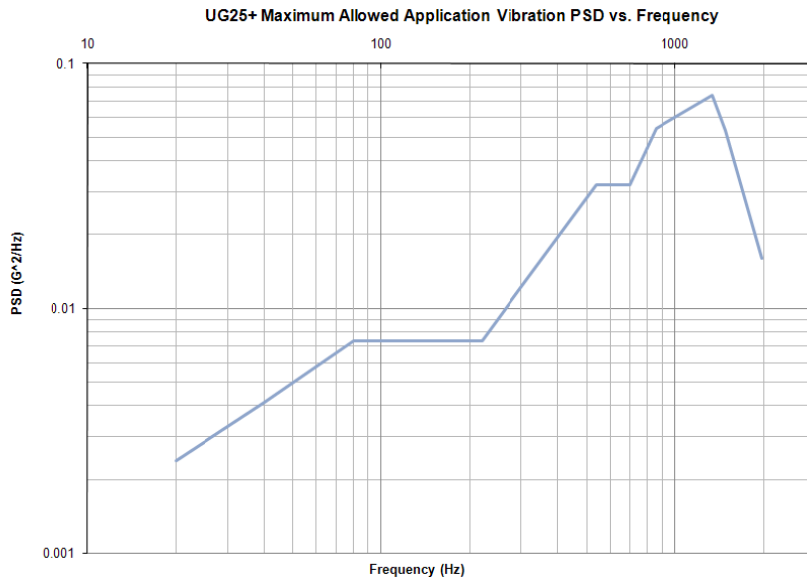

| Frequency (Hz) | Allowed PSD Level (G <sup>2</sup> /Hz) |
|----------------|--|
| 20             | 0.00240                                |
| 40             | 0.00414                                |
| 80             | 0.00736                                |
| 220            | 0.00736                                |
| 540            | 0.03197                                |
| 700            | 0.03197                                |
| 860            | 0.05453                                |
| 1340           | 0.07452                                |
| 1480           | 0.05339                                |
| 1960           | 0.01595                                |

|                    |  |
|--------------------|--|
| Thermal Shock      | SAE J1455, Paragraph 4.1.3.2   |
| Ingress Protection | IP45 for entire unit. IP56 for User Interface per EN60529 and only if proper cable glands are used as described in the technical manual. |

### Regulatory Compliance

#### European Compliance for CE Marking:

EMC Directive: 2004/108/EC

#### Other European Compliance:

(Compliance with the following European Directives or standards does not qualify this product for application of the CE Marking)

Machinery Directive: Compliant as partly completed machinery per 2006/42/EC

Pressure Equipment Directive: Compliant as "SEP" per Article 3.3 to 97/23/EC

#### Marine Compliance:

Models are available that are suitable for marine applications. Contact your sales representative for more information.

Technical Manual 26579



PO Box 1519, Fort Collins CO, USA 80522-1519  
1000 East Drake Road, Fort Collins CO 80525  
Tel.: +1 (970) 482-5811 • Fax: +1 (970) 498-3058  
[www.woodward.com](http://www.woodward.com)

#### Distributors & Service

Woodward has an international network of distributors and service facilities. For your nearest representative, call the Fort Collins plant or see the Worldwide Directory on our website.

This document is distributed for informational purposes only. It is not to be construed as creating or becoming part of any Woodward contractual or warranty obligation unless expressly stated in a written sales contract.

© Woodward 2006, All Rights Reserved

For more information contact:

2012/5/Colorado